



**CAUTION**

Do not use brake to slow down the motor! The brake is only intended for use as a safety brake and must be mounted by Nanotec.

TECHNICAL DATA

	Brake-BWA-0,25-5	Brake-BWA-1,5-6,35
<b>Electrical data</b>	24 VDC/5.9 W	24 VDC/11 W
<b>Switch-on/switch-off time</b>	<100 ms/<10 ms	<100 ms/<30 ms
<b>Hub</b>	Flat-sided (D-Cut) Borehole 5H8 with stud screw	Borehole 6.35H7 with 2x stud screw M3x5
<b>Fastening</b>	With 3 stud screws M3	With 2 stud screws M4
<b>Connection</b>	Leads L=300 mm	Leads L=300 mm

VERSIONS

Type	Supply Voltage V	Holding Torque Ncm	Shaft Diameter mm	Moment of Inertia kg mm <sup>2</sup>	Size mm	Weight kg
BRAKE-BWA-0,25-5	24	25	5	10	35	0.15
BRAKE-BWA-1,5-6,35	24	150	6.35	10	51.5	0.3

DIMENSIONS (IN MM)

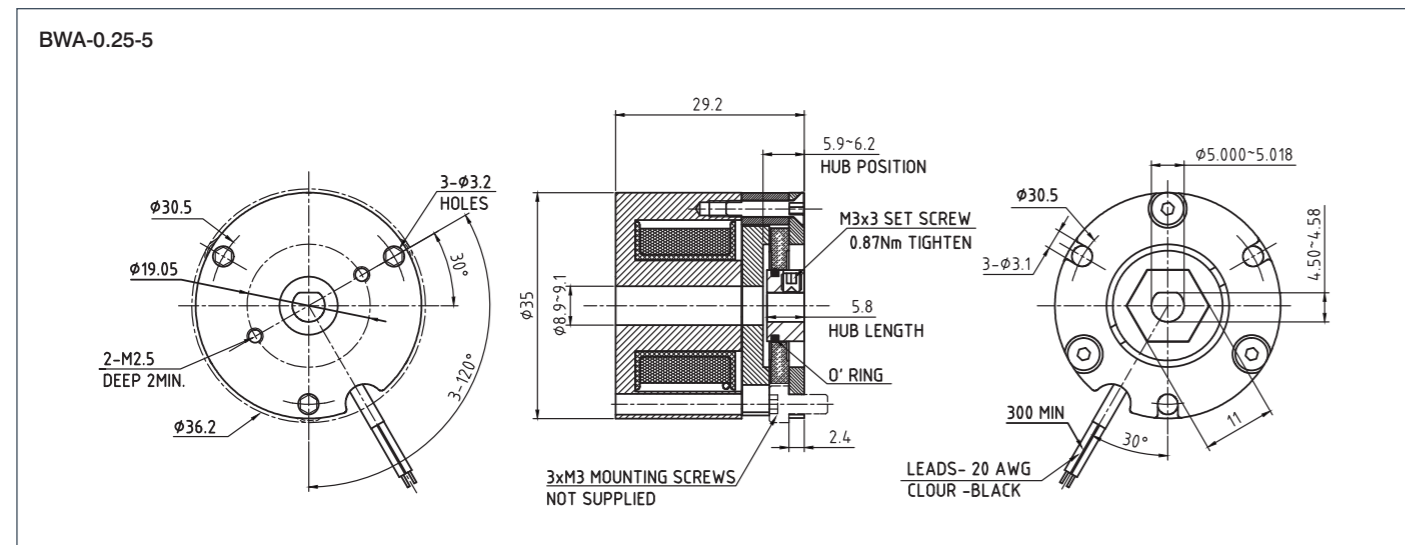

DIMENSIONS (IN MM)

